

E2H

Eccentric Shaft,
Straightside Presses
250–600 Tons Capacity

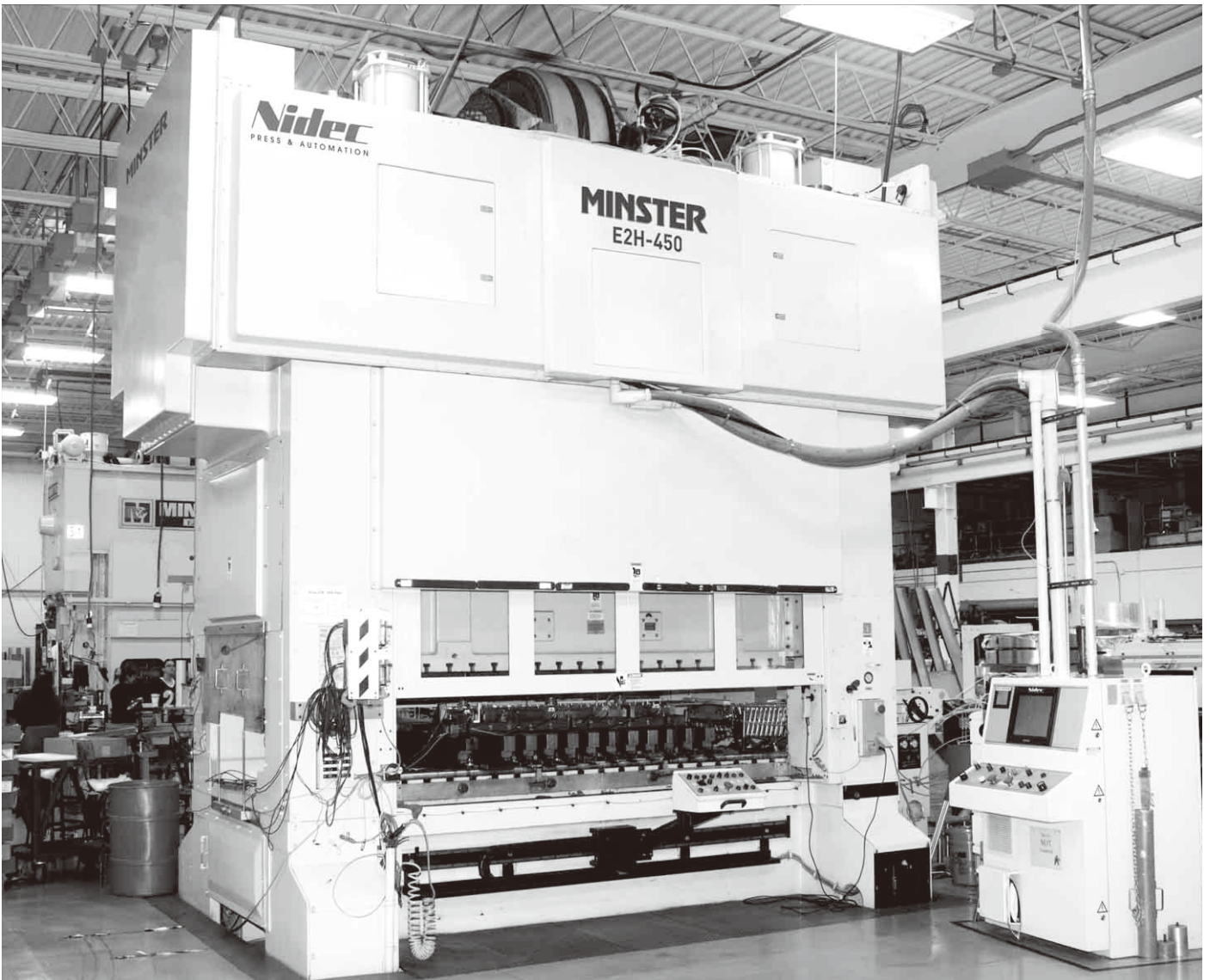

Product Overview

Minster's E2H Series press is designed for today's higher tensile stamping requirements. The E2H has been configured to provide increased energy while operating at higher speeds with larger upright openings and reduced deflections. The E2H offers some of the most technologically advanced features in the material forming industry.



- 1** Additional flexibility and capacity running both large and small dies on the same press.
- 2** Blank high strength material at higher speeds with greater uptime and increased die life.



3 Run progressive and transfer dies with high off-center loading.

5 Perform **in-die sensing** at maximum speed and stop prior to the bottom of the stroke.

4 Increased flexibility with the ability to run high speed dies and lower speed forming dies in the same press.

6 Inspect and trouble-shoot dies and **release jams** faster without adjusting your shutheight.



Standard Features

Massive Frame Construction

The E2H boasts a massive four-piece, pre-loaded frame utilizing high tensile cast iron for the ultimate in vibration and noise dampening. The ultra-low deflection cast bed includes two double walls which reduce front-to-back deflections by 33% over industry standards for general purpose presses. This gives the user the flexibility to run small, full tonnage dies on a large press while maintaining part quality and extending die life.

All E2H presses have large tie rods with rolled threads. Rolled threads are capable of handling up to three times the load of standard cut threads. This added capability is essential in the event of an overload situation.

Eccentric Shaft

Minster's one-piece forged eccentric crankshaft is precision ground, holding high throw-to-throw accuracies that provide superior dynamic parallelism and increased die life in close tolerance dies. Eccentric shafts provide more accuracy and higher rigidity than eccentric gears or crankshafts, and they have approximately 33% more load bearing area and less deflection than a standard crankshaft. This design significantly increases the press's ability to handle snap-thru forces as compared to a crankshaft or eccentric gear design.

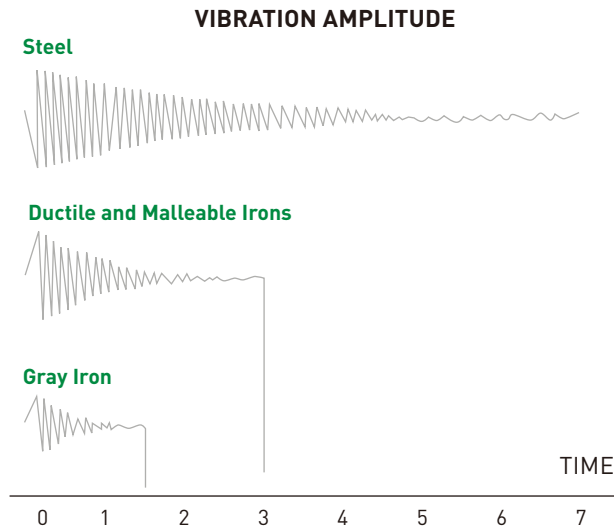

Iron has 2.5 to 4.5 times the dampening capability of steel. Therefore, the E2H utilizes castings in all of its beds, slides and uprights to dampen vibration and noise created in high vibration and snap-thru applications.

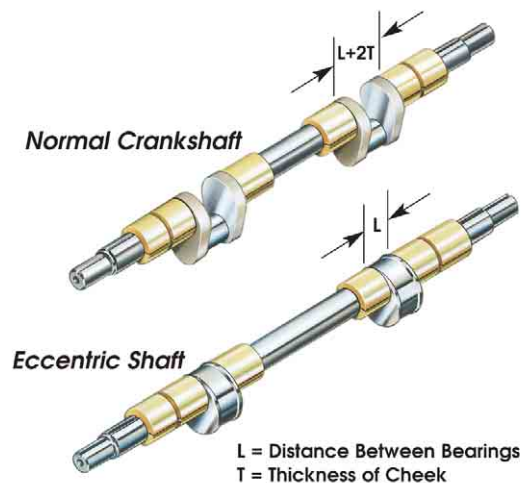
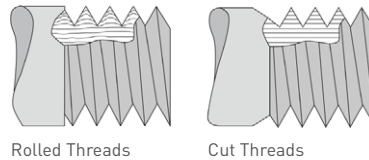

Standard Features

Lower Deflection & Greater Flexibility

Standard presses are designed to have a bed deflection of 0.001" to 0.002" per foot (0,083 to 0,167 mm/M) when full-rated tonnage is distributed over two-thirds of the bed. In addition, the slide deflection of a standard press will be approx. 1.5 times more than the bed deflection. As shown, the E2H has been designed with extremely low deflection providing the ability to run tighter punch-to-die clearance, as well as the flexibility to run small, full tonnage dies on a large press while maintaining part quality and die life.

Four massive, vertical walls of the E2H bed provide low deflection and the ability to run smaller, full tonnage dies.

Circulating oil through the bed assures consistent bed and slide temperatures, which maintain die alignment.

The E2H slide adjustment and quick access assembly are integral to the slide structure. This provides direct support across a wide area of evenly distributed loads, resulting in low deflection and greater resistance to off-center loading.

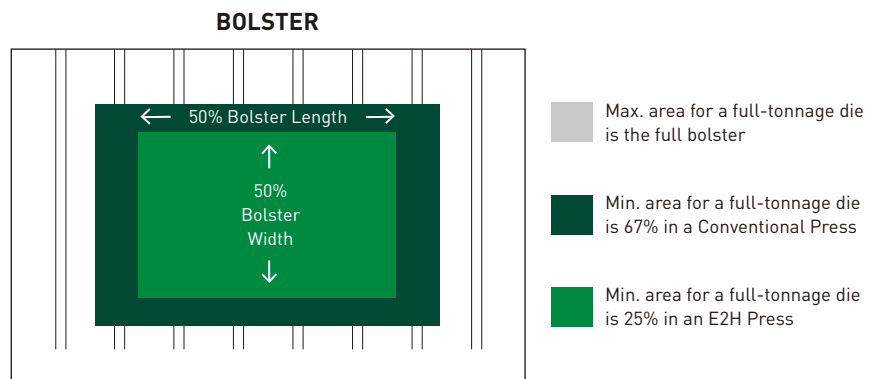

Minimum area for a full-tonnage die in a Minster E2H is almost 50% less than a typical press

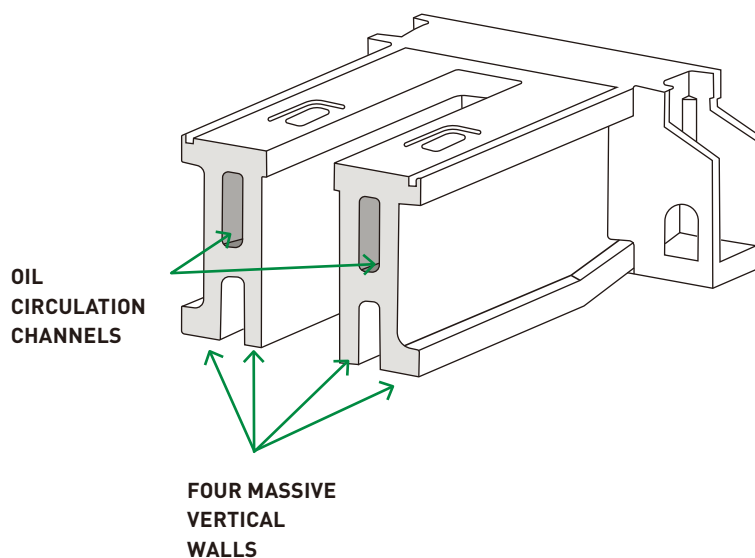

Patented Minster Hydraulic Clutch and Brake Unit

Minster's combination hydraulic clutch and brake produces the maximum torque possible providing for faster starting and stopping, resulting in increased production. A patented segmented drive disc design provides safe and reliable operation, variable clutch torque and easy maintenance. In addition, Minster's clutch and brake unit requires no adjustment and years of maintenance-free operation, resulting in less downtime and higher production rates.

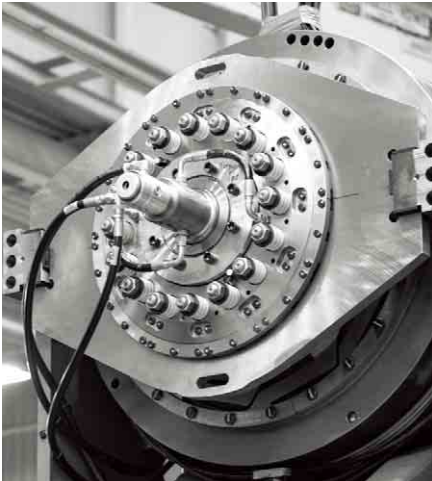

The Minster combination hydraulic clutch and brake provides the ability to single stroke at high rates while simultaneously providing unparalleled stopping time ability that is critical for high speed and in-die sensing applications.

Stopping Angle vs. SPM - E2H-350 with 9.8" (250 mm) Stroke

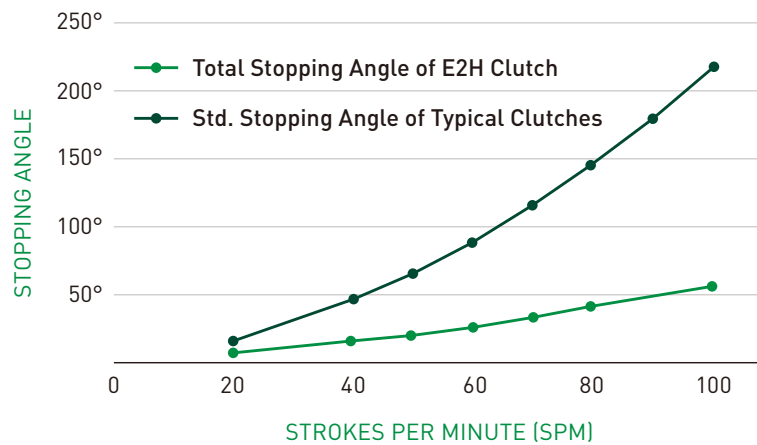

Motorized Slide Adjustment

The slide adjustment on the E2H is driven by a hydraulic motor connected to hardened worm shafts with zero backlash couplings and is supported on anti-friction bearings. The adjustment mechanism includes a shock mounted electronic resolver to display and adjust shuheight on the press console.

Flywheel Brake

The flywheel brake design on the Minster E2H gives the operator the ability to quickly slow the flywheel to a pre-set speed. The combination of an increased brake contact area, reduced surface contact pressure, and increased usable lining thickness provides seven to ten times the life of a normal brake lining.

Standard Features

Drive Arrangement

The Minster E2H utilizes twin helical gears in both its single and double geared arrangements. The advantages of Minster's twin drive arrangement include:

- Improved slide parallelism throughout the working portion of the stroke.
- Virtual elimination of torsional deflection between connections and main bearing maintaining slide parallelism through the working portion of the stroke.
- Improved dynamic parallelism when subjected to off-center loading.
- Decreased punch penetration in snap-thru conditions as a result of twin drive having only 1/2 of torsional wind-up of a typical center drive press with the same size shaft.

In addition, twin drives provide: increased gear life and reduced noise compared to presses utilizing spur gears; and improved gear timing and serviceability as a result of mounting the gears to their shafts without keys.

Torsional Wind-Up Comparison

Finite Element Analysis proves that vertical deflection of a center drive is twice that of a twin drive when maximum rated torque and tonnage are applied evenly to each connection. This results in less stiffness and increased punch penetration in snap-thru applications on a center drive machine.

Full Wrist Pins

Full wrist pins, supplied with high-pressure oil, provide superior snap-thru ratings with reduced wear and deflection. The high tensile stiffness of this design results in improved bottom-dead-center repeatability along with reduced die punch penetration which are critical during high tensile blanking operations. In a snap-thru condition, a wrist pin is subjected to pure shear forces while the connection is only subjected to simple tension forces. Comparatively, when a ball and socket design is subjected to snap-thru, in addition to the shear and tension forces, the ball bushing and retainer are also subjected to bending moments which create a more severe stress situation.

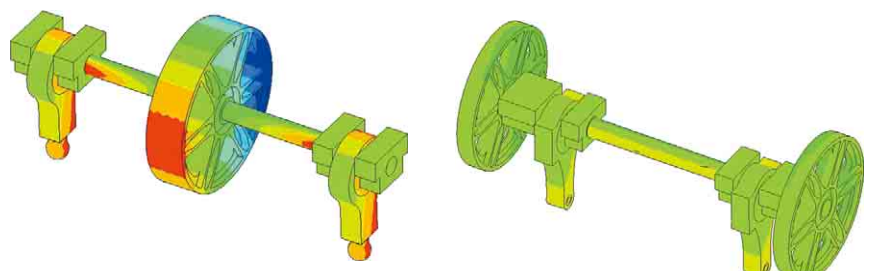
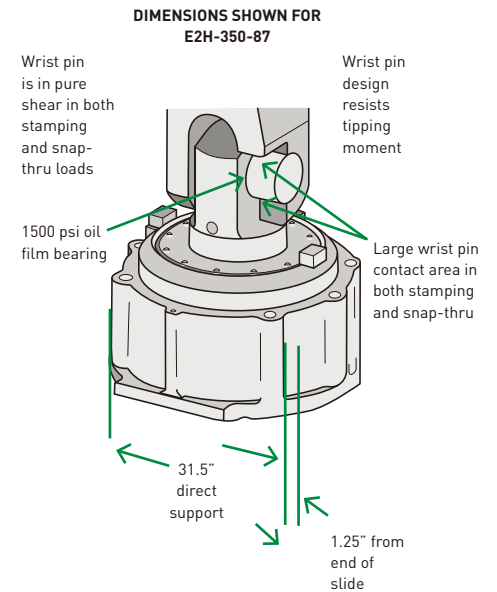

Quick Access Feature

The Quick Access feature on Minster E2H presses enables easy access to the die. Advantages of this feature include:

- Allows the user to raise the slide 3" (75 mm) providing quick and easy access to thread material, inspect the die or release material.
- Eliminates the need for hydraulic tie rod nuts.
- After use, mechanical stops ensure the slide is returned to the exact shutheight position and parallelism that it maintained prior to use. This is not possible with a screw-type mechanism.
- Allows the user to select a press with the minimum stroke length for the application without sacrificing the operator's ability to inspect or change tooling. Utilizing a shorter stroke length minimizes the slide velocity resulting in reduced impact loading, reduced tool vibration, increased tool life and increased production speeds.
- The pressurized quick lift chamber provides a preload exceeding the press tonnage.

Hydraulic Locking

Clearance in the slide adjustment screw and nut mechanism are eliminated by compression of the nut diameter with high pressure oil. This reduces vibrations resulting from snap-thru forces during blanking, improves die life, and eliminates the possibility of the slide adjustment "creeping" under load.

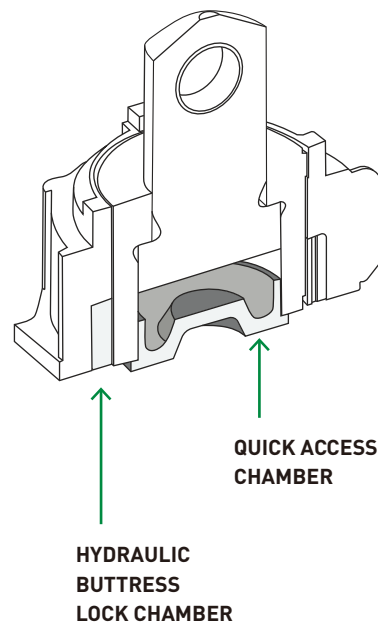

Eight-Point Hydrostatic/Hydrodynamic Gibbing for Precision Slide Guiding

The E2H slide guiding system incorporates both hydrostatic and hydrodynamic bearing technology. This combination of technologies provides:

- Greater resistance to off-center loading than either standard oil film or roller bearing guided gibs
- Extreme overload capacity for shock loading
- Centering of slide in a static condition

The Basics of Hydrostatic/Hydrodynamic Technology

Twelve, separate, hydrostatic pads are machined into the extra-wide gib surfaces of the E2H. When an off-center force attempts to tip the slide, the oil pressures at these pads change independently to offset the force and maintain exceptional slide parallelism.

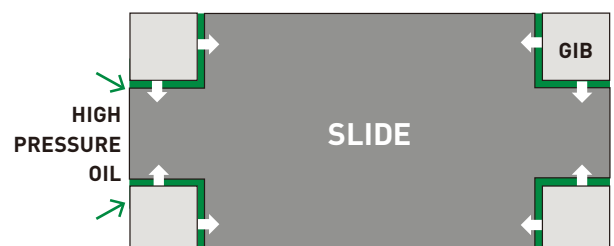

Slide remains centered F-B & R-L with Hydrostatic/Hydrodynamic guiding

Standard Features

Monitored Lubrication with Variable Frequency Regulation

All main and connection bearings have full film lubrication with pressurized oil supplied to each bearing from within the crankshaft. This system is designed to stop the press in the event of reduced oil pressure thereby preventing damage to the machine. A variable speed lube pump motor with pressure transducer feedback maintains constant oil pressure through plant ambient and press temperature variations. The consistent oil film gives the ultimate dynamic bearing stiffness and longevity resulting in better bottom-dead-center repeatability and longer die life.

Hydrodynamic Drive Bearings

Advantages of Hydrodynamic Bearings:

- Infinitely long life with full film lubrication.
- High load capacity.
- Load capacity and stiffness increase w/speed.
- Extreme overload capacity for shock loading.
- High vibration dampening.
- Replacement involves only limited disassembly.

Roller Bearing Weaknesses:

- Will compress five-times more than hydrodynamic gibs when subjected to a high dynamic load.
- Shock load capacity no greater than static load capacity.
- Statistically predictable limited life.
- Severe overloads may produce brinelling.
- Replacement may involve extreme disassembly

Slide Counterbalances

On E2H presses, four counterbalance units mounted in the crown lift at each corner of the slide to eliminate tipping or twisting of the slide. Since each counterbalance rod is free to float in the clamp plate where it is attached to the slide, side forces to the counterbalance piston and the slide are eliminated.

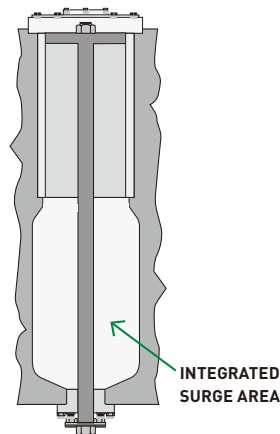

Variable Frequency Drive

As a standard, the E2H utilizes a variable frequency drive (VFD) that is integrated with the PMC control panel. As compared to an eddy current drive motor, a VFD is quieter and provides higher performance throughout the press's full speed range, resulting in lower energy cost for the user. Integrating the VFD with the operator podium reduces the floor space requirements that are typically associated with VFD drives.

Wide Upright Openings

Large upright openings allow feeding of wide material and use of transfer integration.

40% Reverse Load Rating

The combination of the E2H's hydrodynamic drive bearings, forged eccentric shaft, heavy connections, full wrist pins, and slide adjustment screws with hydraulic locked buttress threads, provide the E2H with a 40% reverse load rating (2 to 4 times that of standard presses). This high rating minimizes punch penetration and provides increased capability for blanking and piercing applications.

Isolation Press Mounts

Isolation press mounts are included and standard on Minster E2H presses.



Production Management Control (PMC)

Incorporates all press functions including:

- Full machine diagnostics detailing all press and feed line faults.
- Multiple selectable languages.
- Open architecture which allows for greater convenience in planning and maintenance.
- PLC and color touch screen technology; all press and feed line functions can be monitored for efficient diagnosis of production line faults.

Available popular options include: die protection, load monitoring as well as automatic shutheight and counterbalance controls.

FieldHawk - i4.0

FieldHawk is a cloud-based mobile application designed to communicate with your Nidec stamping press lines from your iOS or Android mobile devices. Cloud-based, secured communications allows all authorized users to check machinery status from anywhere you can get phone service and/or an internet connection, thus reducing downtime.



Optional Features

Alternative Slide Motion

As shown below, the ASM option provides reduced slide velocity through the work portion of the stroke and faster slide velocity through the remaining portion of the stroke as compared to a conventional drive running at the same SPM. If your production can be increased as a result of reduced slide velocity, Minster's ASM was designed to provide you this benefit without changing the overall repeatability, integrity or accuracy of the E2H. Features incorporated into the ASM design include:

- Twin-end drive to maintain performance, reliability, durability, accessibility & accuracy.
- Oil film bearings to assure long life.
- Rotary balanced system to assure press stability.
- Ability to modify ASM velocity curve.

Main Benefits of the ASM Drive include: Slower, more consistent slide velocity through the work angle; and reduced heat generation in the die.

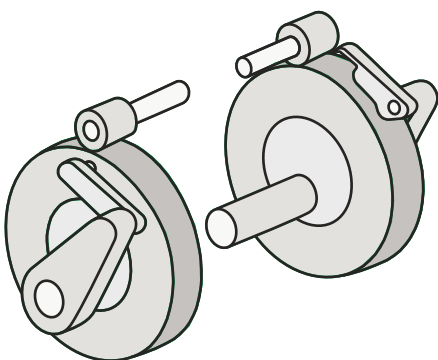

Double Geared Drive

The optional double geared twin drive arrangement is best when slower speeds are required for operations such as deep drawing or forming. In this arrangement, the combination hydraulic clutch and brake unit is mounted on the intermediate shaft (a Minster patented "first") which provides increased single stroke efficiency with less clutch wear.

E2H double gear drives are equipped with the higher off bottom rating and maintain full flywheel energy at slower speeds which decrease the slide velocity and allow for deep drawing and forming applications. This option is available on wider 450 & 600 ton models, and has a speed range of 15-40 SPM.

Crankshaft Extension

Minster provides as standard, one crankshaft extension on the opposite drive side of E2H flywheel presses. This extension is available to drive the user's auxiliary equipment such as feeds, scrap cutters, transfers, etc.

Available as an option on geared drive machines.

Average Work Angle

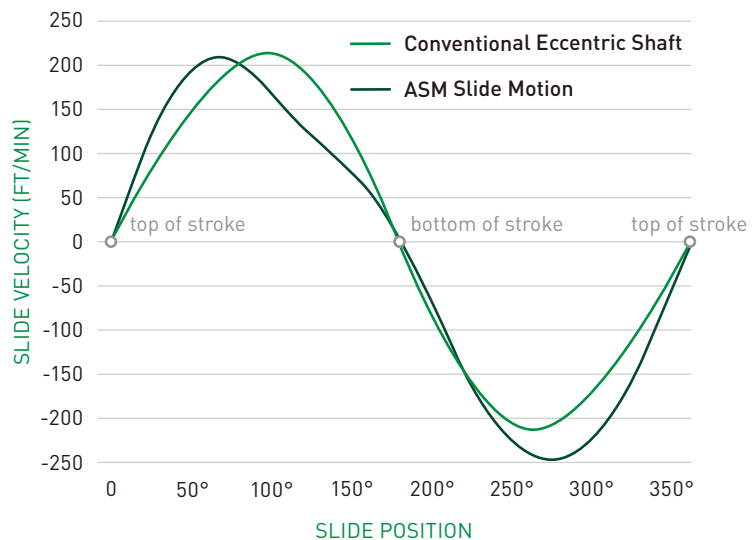

Flywheel Drive Assembly

Minster flywheel drive E2H presses (E2HF models) are available to achieve higher speeds for applications such as blanking.

The clutch and brake unit is mounted on the eccentric shaft and the flywheel rotates on anti-friction bearings.

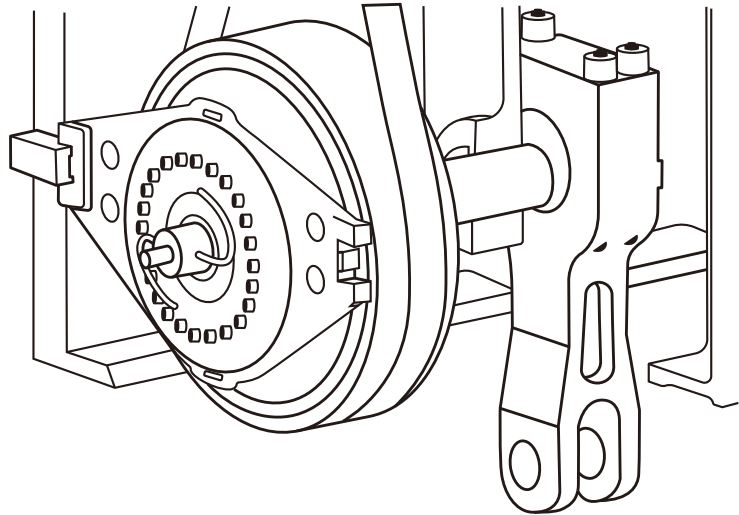

Note: The optional ASM and high energy drive are not available on flywheel drive machines.

Crankshaft Counterweights

Standard crankshaft counterweights on Minster E2HF flywheel presses eliminate any rotary out-of-balance forces. This provides less front-to-back motion, more accurate slide guiding and more accurate feed progressions.

Available as an option on geared drive machines.

Minster Patented VibCoach

Production Vibration Severity Monitoring System provides a continuous “real-time” identification of the long term die & press reliability level. The VibCoach is recommended for presses with normal operations above 200 SPM and can be used with any die operating within the press. VibCoach advises the press operator or production supervisor of any changes in production vibration severity caused by changes in production speed, material, and/or die setup. The VibCoach includes the StatusAlert™ console mounted light tower which provides a quick visual indication of the vibration reliability level during production.

Hydrostatic Gib Monitoring

The optional hydrostatic gib monitoring system is comprised of twelve pressure transducers positioned in the lubrication circuit to sense the gib clearance on both the main and auxiliary gibs. This system will top stop the press if the gibs' clearance is closed-in due to a set up problem or other issue.

Automatic Shutheight Adjustment

To further reduce set-up time, this optional feature will automatically set the shutheight to the predetermined tool storage value. Manual shutheight adjustment can still be achieved via the operator's input on the control.

Optional Features

Hydraulic Overload Protection

The E2H is configured for the addition of a mechanical hydraulic overload system. This quick acting mechanical release is integrated within the PMC Control for ease of use. When an overload condition is detected, the overload valve opens automatically to quickly top stop the press, and activate the quick access slide to protect the press from damage. In addition, unlike conventional overload protecting devices, the E2H slide will open a full 75mm (2.95") to allow quick and easy removal of die jams or other obstructions.

Sliding Set-Up Station

To provide convenience to operators while threading dies, a sliding set-up station is available on E2H presses. The set-up station is capable of sliding across the entire front of the bolster area and can be secured in a home position when not in use.

Increased Rating Higher in the Stroke

Greater distance off bottom provides the capability of carrying a higher load longer and doing work higher off the bottom of the stroke.

Coil Line Interconnects

Die Area Guarding

Additional Part Blow-Off Valves

Choice of Isolation Mounts





One Brand: A World of Resources

Nidec Press & Automation is the full service pressroom provider of choice for businesses in more than 90 countries and on six continents. Comprised of leading press room product brands, we ensure a complete offering of machinery, services and technology to meet your exact needs, enabling you to rely on one source.

Discover the freedom to achieve, to maximize and to drive your operation to exceed your goals. At Nidec Press & Automation, your success is the core of our focus and how we design our solutions to meet the rigid needs of the metal forming industry.

Choosing to work with us means you gain a constant resource with a global footprint, the brightest minds behind our solutions, and backed by regionally based OEM support ready to work as a natural extension of your team.

**Our promise to you is simple:
We're with you whenever and wherever
business takes you.**



MACHINERY

- Turn Key Systems
- Individual Components
- System/Tech Upgrades
- i4.0 Software Upgrades
- Integrated Controls

METAL FORMING PRESS APPLICATIONS

- Mechanical
- Servo
- Transfer
- High-Speed & Electrical
- Electrical Vehicle (EV)
- Lamination
- Container Cupping
- Container End-Conversion
- Container Shell
- Gap/D-Frame

AUTOMATION

- Press Tending / Robotics
- Integrated Transfer
- Systems
- High Speed Servo Feeds
- High Speed Gripper Feeds
- Heavy-Duty Coil Lines

GLOBAL SERVICE NETWORK

- Field Service
- Emergency Response
- Technical Service & Support
- OEM Replacement Parts
- Machine & Component Remanufacturing
- Technical Training

Key Specifications & Dimensions

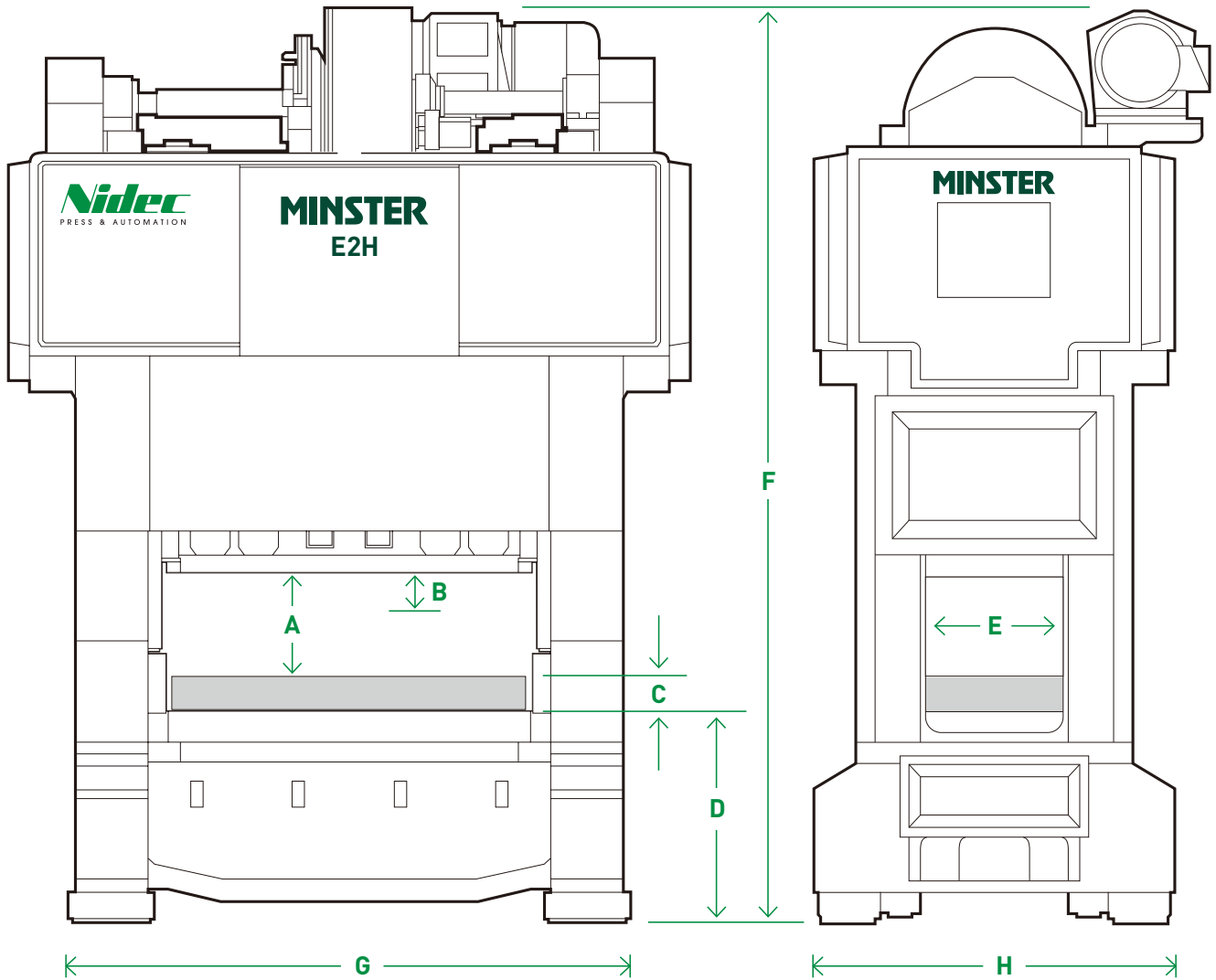

		E2H									
Tonnage	tons/kN	250/2200		350/3100		450/4000			600/5400		
Width	inch/mm	86/2200	120/3050	86/2200	120/3050	100/2550	120/3050	146/3700	120/3050	146/3700	169/4300
A	Shutheight on Bolster (SDAU)	21.65" 550mm	21.65" 550mm	21.65" 550mm	21.65" 550mm	25.20" 640mm	25.20" 640mm		25.98" 660mm	25.98" 660mm	
		23.62" 600mm	23.62" 600mm	23.62" 600mm	23.62" 600mm	29.53" 750mm	29.53" 750mm	29.53" 750mm	31.89" 810mm	31.89" 810mm	31.89" 810mm
		27.56" 700mm	27.56" 700mm	27.56" 700mm	27.56" 700mm	33.86" 860mm	33.86" 860mm	33.86" 860mm	37.80" 960mm	37.80" 960mm	37.80" 960mm
								43.70" 1110mm	43.70" 1110mm	43.71" 1110mm	43.70" 1110mm
B	Shutheight Adjustment	6.88" 175mm	6.88" 175mm	6.88" 175mm	6.88" 175mm	7.87" 200mm	7.87" 200mm	7.87" 200mm	10.24" 260mm	10.24" 260mm	10.24" 260mm
C	Bolster Thickness	6.0"-8.0" 150-205mm	6.0"-8.0" 150-205mm	6.0"-8.0" 150-205mm	6.0"-8.0" 150-205mm	7.0"-8.7" 180-220mm	7.0"-8.7" 180-220mm	6.0"-10.24" 130-260mm	7.0"-9.0" 180-230mm	7.0"-9.0" 180-230mm	7.0"-10.0" 180-255mm
D	Floor To Top Of Bed	42.62" 1085mm	42.88" 1090mm	42.62" 1085mm	42.88" 1090mm	50.75" 1290mm	50.75" 1290mm	60.12" 1525mm	57.75" 1465mm	57.75" 1465mm	60.12" 1525mm
E	Upright Opening	33.50" 850mm	33.50" 850mm	33.50" 850mm	33.50" 850mm	47.50" 1205mm	47.50" 1205mm	64.00" 1625mm	53.50" 1360mm	53.50" 1360mm	76.00" 1930mm
F	Overall Height (Max.)	230" 5850mm	230" 5850mm	232" 5895mm	232" 5895mm	275" 6985mm	275" 6985mm	297" 7545mm	295" 7495mm	298" 7570mm	315" 8000mm
G	Floor Space (R-L)	133.25" 3385mm	166.75" 4235mm	133.25" 3385mm	166.75" 4235mm	160" 4065mm	180" 4575mm	206" 5235mm	180.25" 4580mm	206" 5235mm	230" 5840mm
H	Floor Space (F-B)	85.5" 2170mm	85.5" 2170mm	85.5" 2170mm	85.5" 2170mm	116" 2945mm	116" 2945mm	130" 3300mm	121" 3075mm	121" 3075mm	143.5" 3645mm

		E2HF			
Tonnage	tons/kN	250/2200	350/3100	450/4000	600/5400
Width	inch/mm	79/2000	86/2200	100/2550	120/3050
A	Shutheight on Bolster (SDAU)	17.72" 450mm	17.72" 450mm	18.70" 475mm	23.23" 590mm
		21.65" 550mm	21.65" 550mm	22.64" 575mm	
				26.57" 675mm	
B	Shutheight Adjustment	6.88" 175mm	6.88" 175mm	7.87" 200mm	10.24" 260mm
C	Bolster Thickness	7.09" 180mm	7.09"-8.0" 180mm	7.0"-7.9" 180-200mm	8.0"-9.0" 205-230mm
D	Floor To Top Of Bed	42.62" 1085mm	42.62" 1085mm	50.75" 1290mm	57.75" 1465mm
E	Upright Opening	27.50" 700mm	27.50" 700mm	41.50" 1055mm	47.20" 1200mm
F	Overall Height (Max.)	218.50" 5350mm	218.50" 5350mm	259" 6580mm	280" 7110mm
G	Floor Space (R-L)	133.25" 3385mm	133.25" 3385mm	160" 4065mm	180.25" 4580mm
H	Floor Space (F-B)	85.5" 2170mm	85.5" 2170mm	116" 2945mm	121" 3075mm

		E2H-250			E2H-350		
Drive Type		Geared-Twin Drive			Geared-Twin Drive		
Tons Capacity		250 @ 0.236" or 0.394" ¹ Off Bot. 2225 kN @ 6 or 10mm Off Bot.			350 @ 0.236" or 0.394" ¹ Off Bot. 3100 kN @ 6 or 10mm Off Bot.		
Slide Stroke vs. Speed (SPM)	Stroke	Standard Speed Standard Drive	Maximum Speed ASM Drive	Maximum Speed Standard Drive	Standard Speed Standard Drive	Maximum Speed ASM Drive	Maximum Speed Standard Drive
	2.95" ~ 75 mm	30-100	30-100	65-225	30-100	30-100	65-225
	3.94" ~ 100 mm	30-100	30-100	65-200	30-100	30-100	65-200
	5.91" ~ 150 mm	30-100	30-100	40-150	30-100	30-100	40-150
	7.88" ~ 200 mm	30-100	30-100	40-130	30-100	30-100	40-130
	9.84" ⁴ ~ 250 mm	30-70	30-100	30-100	30-70	30-100	30-100
	11.81" ^{4,5} ~ 300 mm	30-70	30-90	30-90	30-70	30-90	30-90
	13.78" ^{4,5} ~ 350 mm	N/A	N/A	N/A	N/A	N/A	N/A
	15.75" ^{4,5} ~ 400 mm	N/A	N/A	N/A	N/A	N/A	N/A
	17.72" ⁵ ~ 450 mm	N/A	N/A	N/A	N/A	N/A	N/A
Quick Access Slide Travel		2.95" ~ 75 mm			2.95" ~ 75 mm		
Upright Opening		33.50" ~ 850 mm			33.50" ~ 850 mm		
Area of Bolster & Slide (R-L x F-B)		86.6 x 47.5" 2200 x 1205 mm	120.0 x 47.5" 3050 x 1205 mm		86.6 x 47.5" 2200 x 1205 mm	120.0 x 47.5" 3050 x 1205 mm	
Opening in Bed (R-L x F-B)		76.8 x 15.0" 1950 x 380 mm	110.2 x 15.0" 2800 x 380 mm		76.8 x 15.0" 1950 x 380 mm	110.2 x 15.0" 2800 x 380 mm	
Approximate Weight		139,000 Lbs. 63.050 kg	160,000 Lbs. 72.575 kg		149,000 Lbs. 67.580 kg	169,000 Lbs. 76.650 kg	

		E2HF-250		E2HF-350	
Drive Type		Flywheel		Flywheel	
Tons Capacity @ .063" (1,6mm) off bot.		250 ~ 2200 kN		350 ~ 3100 kN	
Slide Stroke vs. Speed (SPM)	Stroke	Speed	Stroke	Speed	
	1.18" ~ 30 mm	65-335	1.18" ~ 30 mm	95-325	
	1.57" ~ 40 mm	65-285	1.38" ~ 35 mm	95-300	
	1.97" ~ 50 mm	65-260	1.57" ~ 40 mm	95-275	
	2.36" ~ 60 mm	65-250	1.97" ~ 50 mm	95-250	
Quick Access Slide Travel		2.95" ~ 75 mm		2.95" ~ 75 mm	
Upright Opening		27.50" ~ 700 mm		27.50" ~ 700 mm	
Area of Bolster & Slide (R-L x F-B)		86.6 x 43.3" 2200 x 1100 mm	120.0 x 47.5" 3050 x 1205 mm	86.6 x 47.5" 2200 x 1205 mm	120.0 x 47.5" 3050 x 1205 mm
Opening in Bed (R-L x F-B)		76.8 x 15.0" 1950 x 380 mm	110.2 x 15.0" 2800 x 380 mm	76.8 x 15.0" 1950 x 380 mm	110.2 x 15.0" 2800 x 380 mm
Approximate Weight		129,000 lbs. 58.510 kg	149,000 lbs. 67.725 kg	130,000 lbs. 59.000 kg	150,000 lbs. 68.100 kg

E2H-450			E2H-600		
Geared-Twin Drive			Geared-Twin Drive		
450 @ 0.236" or .394" ¹ Off Bot. 4000 kN @ 6 or 10mm Off Bot.			600 @ .315" or 0.473" ¹ Off Bot. 53.50 kN @ 8 or 12mm Off Bot.		
Standard Speed Standard Drive	Maximum Speed ASM Drive	Maximum Speed Standard Drive	Standard Speed Standard Drive	Maximum Speed ASM Drive	Maximum Speed Standard Drive
N/A	N/A	N/A	N/A	N/A	N/A
30-100	40-120	40-140	N/A	N/A	N/A
30-90	40-110	40-130	25-70	40-85	40-120
30-80	35-95	40-110	25-70	40-85	40-110
30-70	35-80	30-100	25-70	40-80	40-100
30-60	35-75	30-90	25-60	30-75	25-75
30-60	35-70	30-80	25-60	30-70	25-75
SEE NOTE 4			25-50	30-60	25-70
N/A	N/A	N/A	SEE NOTE 5		
2.95" ~ 75 mm			2.95" ~ 75 mm		
47.50" ~ 1205 mm		64.0" 1625 mm	53.50" 1360 mm		77.0" 1955 mm
100.4 x 55.1" 2550 x 1400 mm	120 x 55.1" ^{2,3} 3050 x 1400 mm	145.7" x 59" ^{2,3} 3700 x 1500 mm	120.0 x 59.0" 3700 x 1500 mm	145.7 x 59" ^{2,3} 3700 x 1500 mm	169 x 75" ^{2,3} 4300 x 1900 mm
90.5 x 20.5" 2300 x 520 mm	110.2 x 20.5" 2800 x 520 mm	135.7 x 22.5" 3450 x 570 mm	110.2 x 22.5" 2800 x 570 mm	135.8 x 22.5" 3450 x 570 mm	136.0 x 30.0" 3455 x 760 mm
250,000 lbs. 113.400 kg	280,000 lbs. 127.000 kg	330,000 lbs. 148.500 kg	334,000 lbs. 151.490 kg	350,000 lbs. 158.800 kg	400,000 lbs. 180.000 kg

E2HF-450		E2HF-600	
Flywheel		Flywheel	
450 ~ 4000 kN		600 ~ 5400 kN	
Stroke	Speed	Stroke	Speed
1.38" ~ 35 mm	85-300	1.18" ~ 30 mm	80-275
1.97" ~ 50 mm	85-275	1.57" ~ 40 mm	80-225
2.95" ~ 75 mm	85-250	1.97" ~ 50 mm	80-200
3.94" ~ 100 mm	85-225	3.94" ~ 100 mm	80-150
2.95" ~ 75 mm		2.95" ~ 75 mm	
41.50" ~ 1055 mm		47.20" ~ 1200 mm	
100.4 x 55.1" 2550 x 1400 mm	120.0 x 55.1" 3050 x 1400 mm	120.0 x 59.0" 3050 x 1500 mm	
90.5 x 20.5" 2300 x 520 mm	110.2 x 20.5" 2800 x 520 mm	110.2 x 22.5" 2800 x 570 mm	
240,000 lbs. 108.900 kg	270,000 lbs. 122.700 kg	285,000 lbs. 129.300 kg	

Notes:

- At higher distances above bottom, lower speeds increase by 5 SPM, with no maximum SPM option available on standard drive presses.
- Double gear option is available in bed sizes (marked 2). Consult Minster for speed ranges. Speed range for all double geared presses is 15-40 SPM.
- Uses steel welded crown.
- Stroke lengths available on E2H-450-146 model. Consult Minster for speed ranges.
- Stroke lengths available on E2H-600-169 model. Consult Minster for speed ranges.
- Maximum SPM reduced by 5 SPM with the ASM option.



One Brand: A World of Resources

A single source solution that will help you find the efficiencies you want — all from the products, services and technology of Nidec Press & Automation.

nidecpa.com